

Icopal Ltd

Barton Dock Road
Stretford
Manchester M32 0YL

Tel: 0161 865 4444 Fax: 0161 864 8433

e-mail: marketing.uk@icopal.com

website: www.decra.co.uk5



Agrément Certificate

95/3122

Product Sheet 4

DECRA ROOFING SYSTEMS

DECRA OBERON TILE

This Agrément Certificate Product Sheet⁽¹⁾ relates to Decra Oberon Tile, aggregate-coated tilesheets preformed from steel coated with zinc, aluminium-zinc alloy, or zinc-aluminium-magnesium alloy, for use on conventional steel or timber roof structures with a minimum pitch of 15°.

(1) Hereinafter referred to as 'Certificate'.

CERTIFICATION INCLUDES:

- factors relating to compliance with Building Regulations where applicable
- factors relating to additional non-regulatory information where applicable
- independently verified technical specification
- assessment criteria and technical investigations
- design considerations
- installation guidance
- regular surveillance of production
- formal three-yearly review.



KEY FACTORS ASSESSED

Weathertightness — the product, used with a suitable underlay, has satisfactory resistance to the passage of rain and snow (see section 6).

Properties in relation to fire — the product is unrestricted under the national Building Regulations (see section 7).

Strength and stability — the product has satisfactory resistance to the effects of wind loading likely to be met in service (see section 8).

Durability — under normal service conditions the product will have a service life in excess of 30 years (see section 11).

The BBA has awarded this Certificate to the company named above for the product described herein. This product has been assessed by the BBA as being fit for its intended use provided it is installed, used and maintained as set out in this Certificate.

On behalf of the British Board of Agrément

Date of Third issue: 5 December 2016

John Albon – Head of Approvals
Construction Products

Originally certificated on 31 March 1995

Claire Curtis-Thomas
Chief Executive

The BBA is a UKAS accredited certification body – Number 113.

The schedule of the current scope of accreditation for product certification is available in pdf format via the UKAS link on the BBA website at www.bbacerts.co.uk
Readers are advised to check the validity and latest issue number of this Agrément Certificate by either referring to the BBA website or contacting the BBA direct.

British Board of Agrément

Bucknalls Lane
Watford
Herts WD25 9BA

tel: 01923 665300

fax: 01923 665301

clientservices@bba.star.co.uk

www.bbacerts.co.uk

©2016

Page 1 of 10

Regulations

In the opinion of the BBA, Decra Oberon Tile, if installed, used and maintained in accordance with this Certificate, can satisfy or contribute to satisfying the relevant requirements of the following Building Regulations (the presence of a UK map indicates that the subject is related to the Building Regulations in the region or regions of the UK depicted):



The Building Regulations 2010 (England and Wales) (as amended)

Requirement:	B3(2)	Internal fire spread (structure)
Requirement:	B4(2)	External fire spread
Comment:	The product is unrestricted under these Requirements. See section 7 of this Certificate.	
Requirement:	C2(b)	Resistance to moisture
Comment:	The product can contribute to satisfying this Requirement. See section 6 of this Certificate.	
Regulation:	7	Materials and workmanship
Comment:	The product is acceptable. See section 11 and the <i>Installation</i> part of this Certificate.	



The Building (Scotland) Regulations 2004 (as amended)

Regulation:	8(1)(2)	Durability, workmanship and fitness of materials
Comment:	The product is acceptable. See sections 10.2 and 11 and the <i>Installation</i> part of this Certificate.	
Regulation:	9	Building standards applicable to construction
Standard:	2.1	Compartmentation
Standard:	2.2	Separation
Comment:	The product can contribute to satisfying these Standards, with reference to clauses 2.1.5 ⁽²⁾ , 2.2.7 ⁽²⁾ and 2.2.10 ⁽¹⁾ . See section 7 of this Certificate.	
Standard:	2.8	Spread from neighbouring buildings
Comment:	The product is unrestricted by this Standard, with reference to clause 2.8 ⁽¹⁾⁽²⁾ . See section 7 of this Certificate.	
Standard:	3.10	Precipitation
Comment:	The product can contribute to satisfying this Standard, with reference to clauses 3.10.1 ⁽¹⁾⁽²⁾ and 3.10.8 ⁽¹⁾⁽²⁾ . See section 6 of this Certificate.	
Standard:	7.1(a)	Statement of sustainability
Comment:	The product can contribute to meeting the relevant requirements of Regulation 9, Standards 1 to 6 and therefore will contribute to a construction meeting a bronze level of sustainability as defined in this Standard.	
Regulation:	12	Building standards applicable to conversions
Comment:	Comments in relation to the product under Regulation 9, Standards 1 to 6 also apply to this Regulation, with reference to clause 0.12.1 ⁽¹⁾⁽²⁾ and Schedule 6 ⁽¹⁾⁽²⁾ .	

(1) Technical Handbook (Domestic)

(2) Technical Handbook (Non-Domestic).



The Building Regulations (Northern Ireland) 2012 (as amended)

Regulation:	23(a)(i)	Fitness of materials and workmanship
Comment:	(iii)(b)(i)	The product is acceptable. See section 11 and the <i>Installation</i> part of this Certificate.
Regulation:	28(b)	Resistance to moisture and weather
Comment:	The product can contribute to satisfying the requirements of this Regulation. See section 6 of this Certificate.	

Regulation:	36(b)	External fire spread
Comment:	The product is unrestricted under these Regulations. See section 7 of this Certificate.	

Construction (Design and Management) Regulations 2015 Construction (Design and Management) Regulations (Northern Ireland) 2016

Information in this Certificate may assist the client, designer (including Principal Designer) and contractor (including Principal Contractor) to address their obligations under these Regulations.

See sections: 1 *Description* (1.2) and 14 *Procedure* (14.6) of this Certificate.

Additional Information

NHBC Standards 2016

NHBC accepts the use of Decra Oberon Tile, provided it is installed, used and maintained in accordance with this Certificate, in relation to *NHBC Standards*, Chapter 7.2 *Pitched roofs*.

CE marking

The Certificate holder has taken the responsibility of CE marking the product in accordance with harmonised European Standard BS EN 14782 : 2006. An asterisk (*) appearing in this Certificate indicates that data shown are given in the manufacturer's Declaration of Performance.

Technical Specification

1 Description

1.1 Decra Oberon Tile is pressed from steel coated with zinc, aluminium-zinc alloy, or zinc-aluminium-magnesium alloy, to a shape simulating eight conventional tiles with profiled interlocking upper and lower edges. The epoxy-primed tilesheets are coated with a mineral-filled acrylic coating incorporating a non-toxic fungicide, followed by stone granules and a clear acrylic glaze (see Figure 1).

Figure 1 Section through Decra Oberon Tile

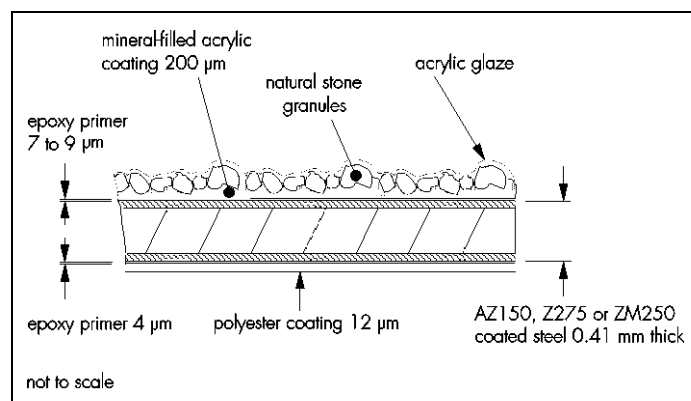

1.2 The product has the characteristics given below:

Thickness of sheet (mm)	0.41
Length of sheet (mm)	1310
Cover length (mm)	1250
Width of sheet (mm)	365
Cover width (mm)	320
Upstand (mm)	25
Minimum side lap (mm)	60
Weight of tile (kg)	2.80

Weight of tiled roof ($\text{kg}\cdot\text{m}^{-2}$)	7.00
Coverage per tile (m^2)	0.39
Colour	Eclipse, Bark, Sunset.

1.3 Accessories⁽¹⁾ with the granulated finish, produced by pressing and coated to the same specification as described in section 1.1, are:

- 'B' ridge/hip cap — to cover 1200 mm
- barge cover with scribed edge — to cover 1104 mm
- side flashing with scribed edge — to cover 1104 mm
- top course flashing — to cover 1200 mm
- 'D' ridge/hip cap — to cover 1200 mm.

(1) Additional purpose-made accessories with matching decorative surfaces are available to order.

1.4 The Certificate holder can supply a guillotine and a tile-bending machine. Other accessories include:

- fixing screws — 35 mm long by 4.2 mm external thread diameter with 6.3 mm diameter head
- Decra fixing nails — flat-headed tile-fixing nails 50 mm long by 2.5 mm diameter, galvanized, serrated or annular grooved and coated with acrylic/bitumen
- finishing kit — pigmented acrylic-based emulsion and matching granules for use on vertically-driven nail heads and to restore damaged areas.

1.5 Other accessories available, but not covered by this Certificate, include:

- special flashings — available to order
- complete roof ventilation systems
- gas flue ridge terminal
- cordless power fastening system.

2 Manufacture

2.1 The product is manufactured from steel sheet which has one of the following coatings to BS EN 10346 : 2015:

- a hot-dip AZ (aluminium-zinc at 55 : 45) alloy coating of $150 \text{ g}\cdot\text{m}^{-2}$
- a Z (zinc) coating of $275 \text{ g}\cdot\text{m}^{-2}$
- a ZM (zinc-aluminium-magnesium) alloy coating of $250 \text{ g}\cdot\text{m}^{-2}$.

The steel coils are slit, guillotined and pressed. The pressed blanks are coated with a polyester coating on the underside and with a pigmented acrylic basecoat incorporating a non-toxic fungicide on the weather side. Ceramic glazed schist stone granules, spray-coated with a clear acrylic glaze incorporating a UV inhibitor, are applied, and the tiles are oven cured.

2.2 As part of the assessment and ongoing surveillance of product quality, the BBA has:

- agreed with the manufacturer the quality control procedures and product testing to be undertaken
- assessed and agreed the quality control operated over batches of incoming materials
- monitored the production process and verified that it is in accordance with the documented process
- evaluated the process for management of nonconformities
- checked that equipment has been properly tested and calibrated
- undertaken to carry out the above measures on a regular basis through a surveillance process, to verify that the specifications and quality control being operated by the manufacturer are being maintained.

2.3 The management systems of Icopal SA have been assessed and registered as meeting the requirements of EN ISO 9001 : 2008 by BCCA (Certificate BQ700-0325).

2.4 The product is manufactured in Belgium and marketed/distributed in the UK by Decra Roof Systems Ltd (a member of the Icopal Group), Unit 4, Crompton Way, Crawley, West Sussex RH10 9QB; tel: 01293 545058; fax: 01293 562709; e-mail: sales@decra.co.uk; website: www.decra.co.uk

3 Delivery and site handling

3.1 Tiles are delivered to site in packs of up to 280, on specially-designed timber pallets giving protection to the edges and corners of the tiles.

3.2 On site the pallets should be stored on a firm, dry base away from the possibility of damage, covered to prevent water ingress, and as close as possible to the building where they are to be installed. Pallets of tiles may be stacked two units high.

Assessment and Technical Investigations

The following is a summary of the assessment and technical investigations carried out on Decra Oberon Tile.

Design Considerations

4 Use

4.1 Decra Oberon Tile is satisfactory for use, in conjunction with a suitable underlay material, as a weatherproof and decorative covering on a conventional timber or steel structure with a minimum pitch of 15°.

4.2 To prevent electro-chemical corrosion, direct contact with copper or its alloys should be avoided and copper roofs should not drain onto the installation.

5 Practicability of installation

The product should only be installed by roofers/tilers trained and approved by the Certificate holder.

6 Weathertightness



The tiles, used with a suitable underlay, have satisfactory resistance to the passage of rain and snow.

7 Properties in relation to fire



When tested to BS 476-3 : 1958 with a bitumen felt underlay, the tiles achieved an EXT.S.AAX fire rating. The performance of the tiles without an underlay was assessed and an EXT.S.AA rating given.

8 Strength and stability

8.1 The tiles have satisfactory resistance to the effects of wind suction likely to be met in service.

8.2 The tiles weigh considerably less than conventional roofing materials, and the roof substructure should be securely attached to the structure of the building to prevent wind uplift under adverse conditions.

9 Resistance to damage

9.1 The tile will not be deformed by normal maintenance traffic.

9.2 The tiles can be deformed by impact.

10 Maintenance

10.1 For maintenance work, roof ladders or crawling boards should be used, but care is still required to prevent damage. It is recommended that soft-soled shoes are worn.



10.2 Small areas where the coating has been damaged should be re-coated using the finishing kit.

10.3 Damaged tiles can be replaced but care should be taken to prevent damage to adjacent tiles.

11 Durability



11.1 The epoxy, polyester, mineral-filled acrylic and galvanizing coatings will protect the steel substrate against corrosion and will give the product a life in excess of 30 years.

11.2 Localised maintenance treatment may be necessary within 30 years to restore the appearance where chippings may have been lost or the coating eroded.

12 Reuse and recyclability

The product contains steel, which can be recycled.

Installation

13 General

13.1 The standard of installation of Decra Oberon Tile should comply with the requirements of BS 8000-6 : 2013.

13.2 The tiles can be installed at all temperatures likely to be met in roofing works. However, at temperatures below -10°C extra care is required, particularly when driving nails and cutting and bending tiles.

13.3 The roof construction must be adequate to resist the loadings detailed in BS EN 1991-1-1 : 2002 and BS EN 1991-1-4 : 2005 and their UK National Annexes, or BS 6399-1 : 1996 and BS 6399-2 : 1997. The roof construction should be in accordance with the relevant requirements of BS 5534 : 2014.

13.4 The minimum batten sizes permitted depend on the rafter spacing, as detailed in Table 1.

Table 1 Batten sizes and rafter or roof truss centres

Minimum batten size (mm)	Rafter spacing (mm)
38 x 25	450
50 x 25	600
50 x 50	900
50 x 50	1200
65 x 50	1500

13.5 The roof space and batten space must be adequately ventilated in accordance with BS 5250 : 2011.

13.6 Where timber boarding is laid on the rafters, a timber counter batten should be installed in accordance with BS 5534 : 2014.

13.7 The underlay must be to BS 8747 : 2007 Annex B, Type 1F or 5U, or be covered by an Agrément Certificate and installed in accordance with that Certificate.

14 Procedure

14.1 Rafters must be securely tied to the building structure with, for example, galvanized steel straps complying with BS EN 1996-1-1 : 2005, BS EN 1996-2 : 2006 or PD 6697 : 2010.

14.2 Where the rafters/trusses are spaced at 900 mm, 1200 mm or 1500 mm centres, polypropylene or nylon tape is nailed across the rafters to support the underlay.

14.3 Battens are secured over the underlay and roof trusses and fixed at the spacings given in Figure 2. The fixings used to secure the battens to the rafters must be adequate to resist predicted wind loads.

Figure 2 Spacing details

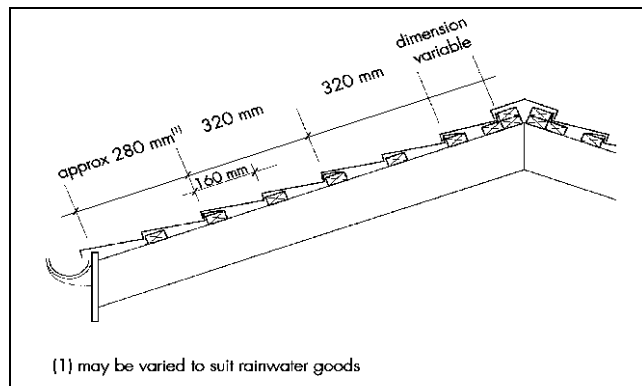

14.4 The tiles are laid onto the battens with the front flange of the upper tile overlapping the rear upstand of the lower tile. Adjacent tiles are overlapped with side laps of 60 mm (one corrugation) (see Figures 2 and 3).

Figure 3 Overlap details

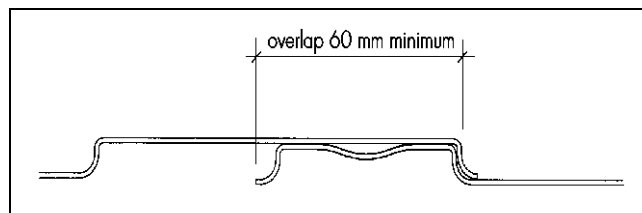

14.5 Fixing is achieved by nailing through the front downturned flange into the side of the batten using Decra nails at the rate of four per tile (see Figures 2, 4 and 5).

Figure 4 Overlap and nailing points

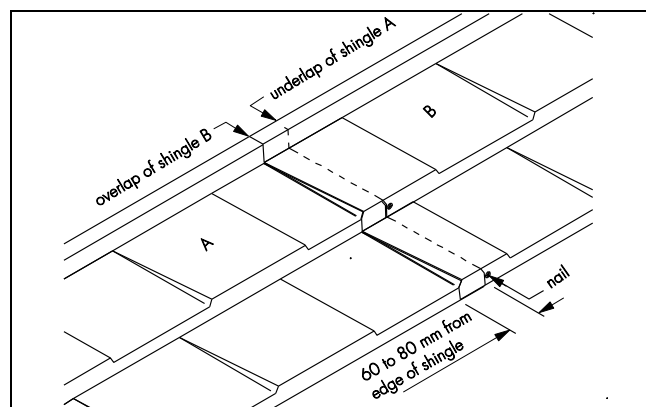
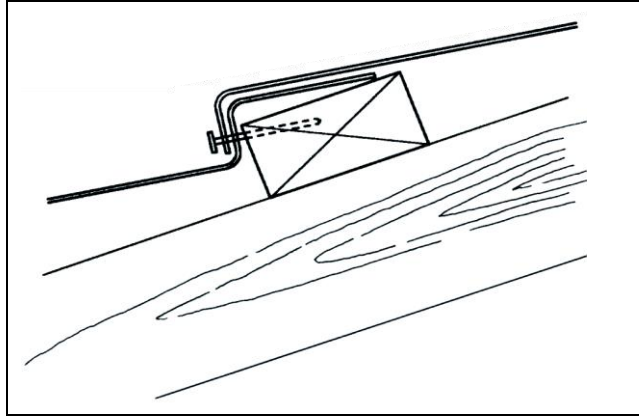

Figure 5 Fixing details



14.6 Tiles are preferably cut and formed with a guillotine and a tile-bending machine, but small quantities may be cut with tin snips or sheet metal cutters, and bent by hand.

14.7 The accessories are cut, formed and installed as necessary to complete the installation.

Technical Investigations

15 Tests

Tests were carried out and the results assessed to determine:

- resistance to bending
- resistance to thermal effects
- inter-coat adhesion
- resistance to salt spray
- resistance to artificial weathering
- life of fixings
- strength of tiles
- resistance to rain penetration
- resistance to impact damage
- corrosion resistance
- resistance to loading
- effect of condensation
- resistance to wind uplift.

16 Investigations

16.1 An assessment was made of fire tests to BS 476-3 : 1958.

16.2 The manufacturing process was evaluated, including the methods adopted for quality control, and details were obtained of the quality and composition of the materials used.

16.3 Visits were made to sites in progress to assess the practicability of installation and ease of repair.

16.4 Relevant data were examined from the BBA's previous assessments of the Decramastic Lightweight Roofing System, the Decracrylic Lightweight Roofing System and Decra Roof Tiles, the subjects of Agrément Certificates 78/582, 86/1641 and 90/2559 respectively.

Bibliography

- BS 476-3 : 1958 *Fire tests on building materials and structures — External fire exposure roof test*
- BS 5250 : 2011 *Code of practice for control of condensation in buildings*
- BS 5534 : 2014 *Code of practice for slating and tiling (including shingles)*
- BS 6399-1 : 1996 *Loading for buildings — Code of practice for dead and imposed loads*
- BS 6399-2 : 1997 *Loading for buildings — Code of practice for wind loads*
- BS 8000-6 : 2013 *Workmanship on building sites — Code of practice for slating and tiling of roofs and cladding*
- BS 8747 : 2007 *Reinforced bitumen membranes (RBMs) for roofing — Guide to selection and specification*
- BS EN 1991-1-1 : 2002 *Eurocode 1: Actions on structures — General actions — Densities, self-weight, imposed loads for buildings*
- NA to BS EN 1991-1-1 : 2002 *UK National Annex to Eurocode 1: Actions on structures — General actions — Densities, self-weight, imposed loads on buildings*
- BS EN 1991-1-4 : 2005 *Eurocode 1 : Actions on structures — General actions — Wind actions*
- NA to BS EN 1991-1-4 : 2005 *UK National Annex to Eurocode 1: Actions on structures — General actions — Wind actions*
- BS EN 1996-1-1 : 2005 *Eurocode 6: Design of masonry structures — General rules for reinforced and unreinforced masonry structures*
- BS EN 1996-2 : 2006 *Eurocode 6: Design of masonry structures — Design considerations, selection of materials and execution of masonry*
- BS EN 10346 : 2015 *Continuously hot-dip coated steel flat products — Technical delivery conditions*
- BS EN 14782 : 2006 *Self-supporting metal sheet for roofing, external cladding and internal lining — Product specification and requirements*
- EN ISO 9001 : 2008 *Quality management systems — Requirements*
- PD 6697 : 2010 *Recommendations for the design of masonry structures to BS EN 1991-1-1 and BS EN 1996-2*
- LPS1175 : 2007 *Specification for testing and classifying the burglary resistance of building components, strong-points and security enclosures*

17 Conditions

17.1 This Certificate:

- relates only to the product/system that is named and described on the front page
- is issued only to the company, firm, organisation or person named on the front page – no other company, firm, organisation or person may hold claim that this Certificate has been issued to them
- is valid only within the UK
- has to be read, considered and used as a whole document – it may be misleading and will be incomplete to be selective
- is copyright of the BBA
- is subject to English Law.

17.2 Publications, documents, specifications, legislation, regulations, standards and the like referenced in this Certificate are those that were current and/or deemed relevant by the BBA at the date of issue or reissue of this Certificate.

17.3 This Certificate will remain valid for an unlimited period provided that the product/system and its manufacture and/or fabrication, including all related and relevant parts and processes thereof:

- are maintained at or above the levels which have been assessed and found to be satisfactory by the BBA
- continue to be checked as and when deemed appropriate by the BBA under arrangements that it will determine
- are reviewed by the BBA as and when it considers appropriate.

17.4 The BBA has used due skill, care and diligence in preparing this Certificate, but no warranty is provided.

17.5 In issuing this Certificate the BBA is not responsible and is excluded from any liability to any company, firm, organisation or person, for any matters arising directly or indirectly from:

- the presence or absence of any patent, intellectual property or similar rights subsisting in the product/system or any other product/system
- the right of the Certificate holder to manufacture, supply, install, maintain or market the product/system
- actual installations of the product/system, including their nature, design, methods, performance, workmanship and maintenance
- any works and constructions in which the product/system is installed, including their nature, design, methods, performance, workmanship and maintenance
- any loss or damage, including personal injury, howsoever caused by the product/system, including its manufacture, supply, installation, use, maintenance and removal
- any claims by the manufacturer relating to CE marking.

17.6 Any information relating to the manufacture, supply, installation, use, maintenance and removal of this product/system which is contained or referred to in this Certificate is the minimum required to be met when the product/system is manufactured, supplied, installed, used, maintained and removed. It does not purport in any way to restate the requirements of the Health and Safety at Work etc. Act 1974, or of any other statutory, common law or other duty which may exist at the date of issue or reissue of this Certificate; nor is conformity with such information to be taken as satisfying the requirements of the 1974 Act or of any statutory, common law or other duty of care.